

KEL-C100 Stainless Steel AirFlow Oven Cart

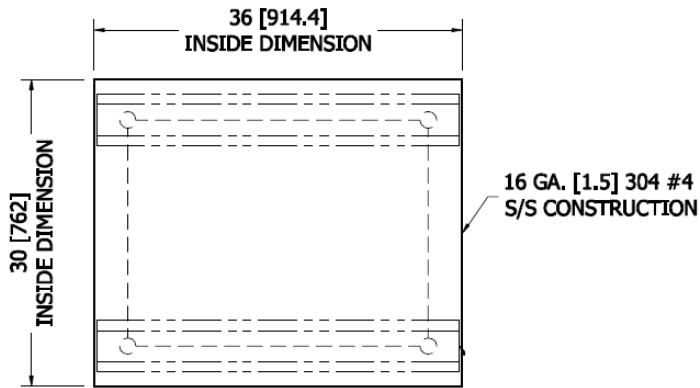

PLAN VIEW

Item	Description
KEL-C100	SS Airflow Oven Cart (Cart and Casters)
KEL-101	30"x36" 16 Gauge SS Cart (Cart Only with adj Feet)
KEL-102	5"Oven Cart Casters

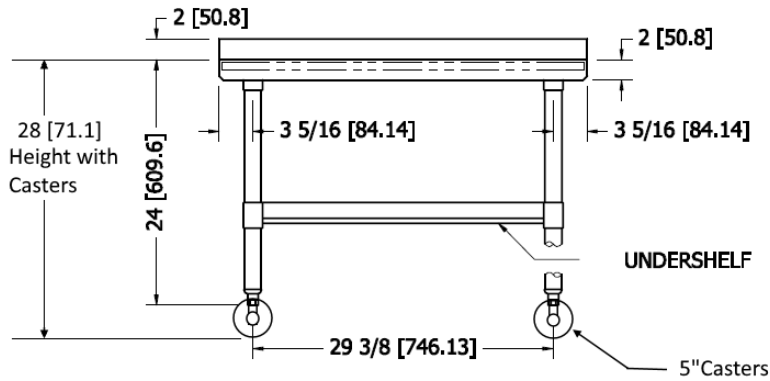

FRONT VIEW

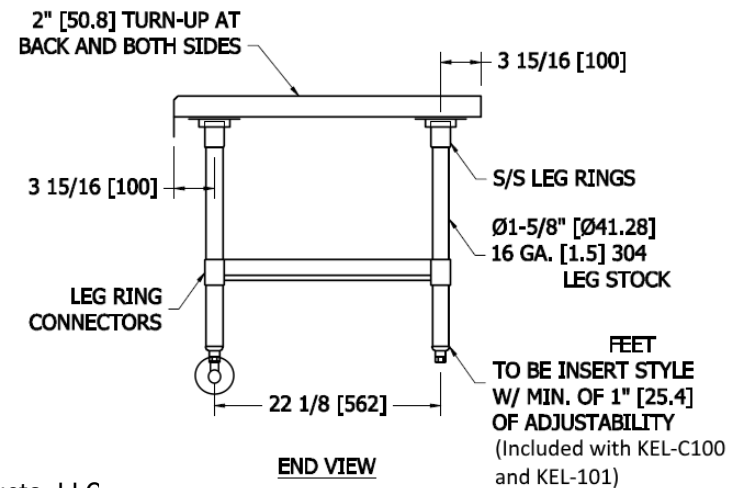

END VIEW