

# Co-60 in HDR Brachytherapy

## Confidence Through Experience

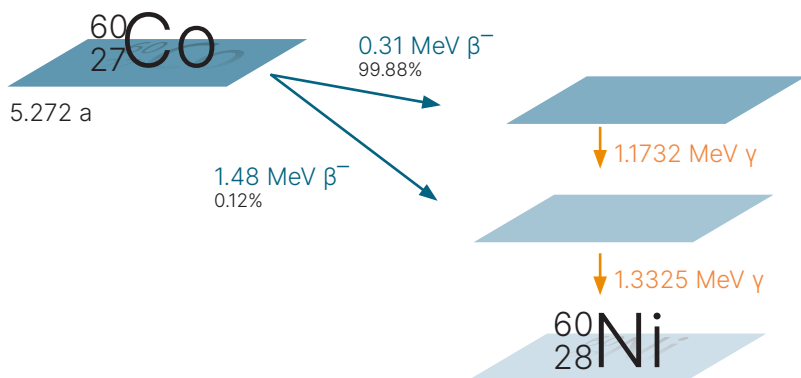

### Cobalt-60

The well established and clinically proven isotope for all HDR brachytherapy treatments.

Cobalt-60 sources are available for BEBIG Medical afterloaders.

### HDR Brachytherapy Started with Cobalt-60

In 1962, Walstam [1] introduced the first concept of a remote afterloader equipped with Co-60. Since its introduction, Co-60 has achieved tremendous success and has continued to evolve to support modern HDR brachytherapy needs. In 2003, Eckert & Ziegler BEBIG successfully designed and introduced the first miniaturized Co-60 source. This design, advanced even by today's standards, enables treatment with applicators of the smallest diameters and narrow curvatures. To date, more than 270 BEBIG Medical afterloaders equipped with Co-60 have been installed worldwide and continue to prove their outstanding reliability.

### Clinically Sound with Proven Physics

The Co-60 source is not only clinically [11] [12] [13] [14] well proven, it is physically [2] [3] [6] well understood and extensively analyzed as well. Accordingly, TG-43 data (Dosimetry of interstitial brachytherapy sources: Recommendations of the AAPM Radiation Therapy committee Task Group 43), dosimetric measurements, and Monte Carlo calculations [4] [7] [8] [9] [10] are available and have been implemented in HDRplus [5] and SagiPlan<sup>®</sup>. The treatment planning systems of BEBIG Medical are able to calculate dose distributions of Co-60 for all applicators shielded and unshielded.

### Complete Range of Clinical Applications

Co-60 has been shown to be a good choice for treating gynecological, rectal, prostate, breast, esophagus, skin, and other body sites. BEBIG Medical provides customers with an expansive portfolio of applicators suitable for the use with Co-60 and Ir-192.

### Favorable Dose to Organs at Risk

The treatment with Co-60 leads to lower dose to organs at risk (OAR) than with Ir-192. Due to its higher mean energy of 1.25 MeV, less scatter is produced and therefore, the radial dose function of Co-60 shows slightly smaller values than Ir-192 with 0.35 MeV (see figure 1). This leads to less dose to organs at risk or healthy tissue within approx. 20 cm from the source<sup>1</sup>.

### Source Exchange Period up to 5 Years

Due to the long half life of Co-60, the source can be used for up to 5 years which means that during the recommended working life of a single Co-60 source, approximately 20 source exchanges of Ir-192 would have to be performed. The significant time saved in performing quality assurance checks after each source exchange makes the use of Co-60 particularly attractive for high volume clinics. Furthermore, Co-60 is the isotope of choice for countries with demanding logistics.

### Treatment Time

The BEBIG Medical Co-60 source is loaded with an activity of up to 81.4 GBq which is significantly lower than an Ir-192 source, with up to 481 GBq. However, the Co-60 dose rate is only slightly lower due to the higher air kerma rate constant (306 vs. 110  $\mu\text{Gy} \cdot \text{m}^2 \cdot \text{GBq}^{-1} \cdot \text{h}^{-1}$ ). Therefore, the total treatment time with Co-60 is only slightly longer than with Ir-192. Nevertheless, if preferred, the source exchange period can be shortened to speed up treatment time.

### Robust Capsule Design

The capsule design of the BEBIG Medical Co-60 source fulfills the demanding regulatory and governmental requirements of EU, North American, and other nations. Moreover, the unique source capsule shows outstanding wear resistance and a low friction factor due to well-engineered plasma nitride hardening. The capsule and the source wire are connected by a hightech laser welding method and designed to stand 100,000 source transfers. This has been proven by stress tests in straight and curved applicators exceeding this figure to ensure safety and long-term precision<sup>2</sup>. With 100,000 cycles in five years, a clinic could have theoretically up to 7 patients a day<sup>3</sup> receiving a 10 channel interstitial treatment or 24 patients a day<sup>3</sup> for the treatment with a three-channel applicator. However, the user is always informed about the current numbers of cycles by the afterloaders software to ensure compliance with the maximum value.

## Radial Dose Function

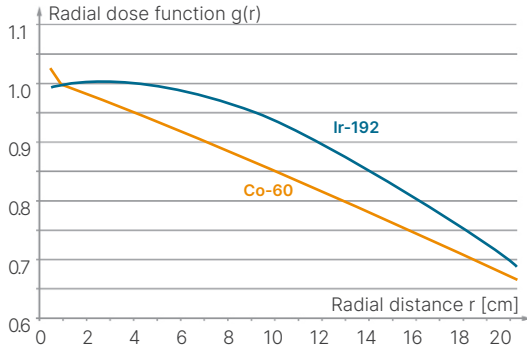

Figure 1: Radial dose functions demonstrate the favorable steep dose fall off of Co-60 compared to Ir-192.

## Certified ISO 2919 Class 65444

The BEBIG Medical Co-60 source and its capsule have been tested successfully according to ISO 2919 and certified as class 65444. The capsule has proven to withstand a temperature range of -40°C to +800°C, external pressure test up to 170 MPa, impact test of 2 kg, vibration test from 25 Hz to 2000 Hz, and puncture test of 50g.

## Shielding Requirements

Like any medical device utilizing radiation, afterloaders equipped with Co-60 require a shielded treatment room to provide radiation protection. In many cases, customers may choose to install the afterloader in existing bunkers already in use with teletherapy devices to more quickly begin to treat patients. If a new brachytherapy suite is required, BEBIG Medical will provide customers with input on constructional drawings regarding shielding, e.g. wall thickness and materials. Furthermore, BEBIG Medical also can support customers in their efforts to obtain any new licenses needed to satisfy local requirements.

## Possibility to Choose

BEBIG Medical offers the choice between two isotopes for HDR brachytherapy: Co-60 or Ir-192. Should a customer wish to change the isotope from the one initially chosen for initial treatments, BEBIG Medical can make this possible with-out changing all of the applicators and accessories already purchased<sup>4</sup>.

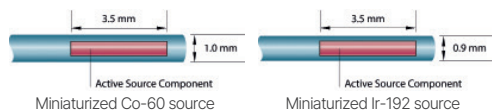

1 Dose to organs at risk more than 20 cm distant from the source are negligible (0.2 % dose relative to dose at 1 cm). 2 Stress tests were carried out by BEBIG Medical. Documentation is available upon request. 3 Assuming 5 work days per week. 4 This option has to be included in the original order for the afterloader due to different source containers.

SagiNova and SagiPlan are registered trademarks of BEBIG Medical and its subsidiaries. The mentioned products are not available in all markets. Please contact your local BEBIG Medical representative for more information.

## Source Anisotropy

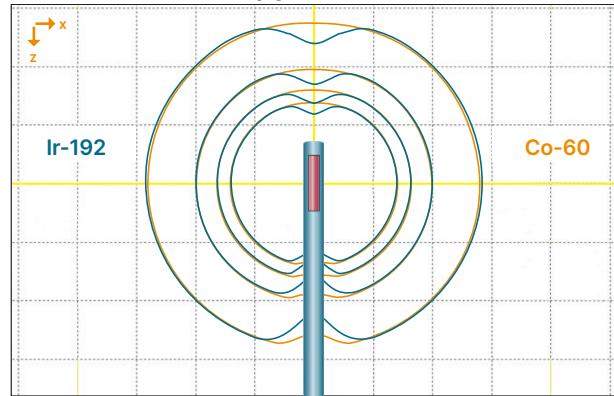

Figure 2: The anisotropy function of Co-60 leads to an advantageous dose distribution closer to the distribution of a point source.

[1] Walstam R, Remotely-controlled afterloading apparatus (a preliminary report), Phys. Med. Biol. 7: 225-8

[2] G. A. Zakaria et al, Dosimetry of HDR afterloading machines with Ir-192- und Co-60-sources: Comparison of different international protocols, Z. Med. Phys. 20 (2010) 215-224

[3] J. Richter et al, Comparison of 60Cobalt and 192Iridium Sources in High Dose Rate Afterloading Brachytherapy, Strahlenther. Oncol. 184 (2008) 187-192

[4] M. Anwarul Islam et al, Dosimetric comparison between the microSelectron HDR 192Ir v2 source and the BEBIG 60Co source for HDR brachytherapy using the EGSnrc Monte Carlo transport code, J Med Phys Vol37 No4 (2012) 219-225

[5] A. Palmer et al, Treatment planning study of the 3D dosimetric differences between Co-60 and Ir-192 sources in high dose rate (HDR) brachytherapy for cervix cancer, J. Contemp. Brachyther. Vol4 No1(2012) 52-59

[6] S. Strohmaier et al, Comparison of 60Co and 192Ir sources in HDR brachytherapy, J Contemp Brachyther. Vol3 No4 (2011) 199-208

[7] S. Sahoo et al, Monte Carlo modeling of Co60 HDR brachytherapy source in water and in different solid water phantom materials, J Med Phys, Vol35No1(2009) 15-22

[8] T. Palani Selvam et al, Technical Note: EGSnrc based dosimetric study of the BEBIG 60Co HDR brachytherapy sources, Am. Assoc. Phys. Med. Vol37 No3 (2010) 1365-1370

[9] D. Graneo et al, Technical note: Dosimetric study of new Co-60 source used in brachytherapy, Am. Assoc. Phys. Med. Vol34 No9 (2007) 3485-3488

[10] Ballester et al, Monte Carlo dosimetric study if the BEBIG Co-60 HDR source, Phys. Med. Biol. Vol50 (2005) N309-N316

[11] C.A.F. Joslin et al, The treatment of cervix cancer using high activity Co-60 sources, British Journal of Radiology 45 (1972) 257-270

[12] Hee-Chul Park et al, Fractionated High-Dose-Rate Brachytherapy in the Management of Uterine Cervical Cancer, Yonsei Medical Journal Vol43 No6 (2002) 737-748

[13] Vicharn Lorvidhaya et al, High-Dose-Rate afterloading brachytherapy in carcinoma of the cervix: an experience of 1992 patients, Int J Radiation Oncology Biol Phys Vol46 No5 (2000) 1185-1191

[14] M. Chatani et al, Long term follow-up results of High-Dose-Rate remote afterloading intracavitary radiation therapy for carcinoma of the uterine cervix, Strahlentherapie und Onkologie Vol170 No5 (1994)

**Manufacturer:**  
**BEBIG Medical GmbH**  
 Robert-Rössle-Str. 10  
 13125 Berlin  
 Germany

Phone +49 30 9487888-10  
 sales@bebigmedical.com

### Regional sales, marketing, and service in US

**Klarity**  
 600 Industrial Parkway  
 Heath, OH 43056  
 Phone 740 788 8107  
 Fax 740 788 8109  
 info@klaritymedical.com  
 www.klaritymedical.com

